

Realistic tests in all speed ranges Highly flexible HP Coupling



Advantages

- + Close to real life testing
- + Increased lifetime of all test rig components
- + Allows high-speed testing up to 8 500 rpm
- + Specially designed for bell-house arrangements
- + Maximum availability and low operating costs
- + Wear-free design
- + Minimized power loss

Voith HP Coupling protects the test rig against damaging torsional vibrations and natural frequencies.

The further enhanced Voith Hydrodamp vibration damper secures the driveline of a test rig even at high speeds and temperatures. The HP Coupling offers customized and fine adjusted spring assemblies and is adaptable to all customer connections. This allows test rig operators to test engines under realistic conditions.

In the automotive industry, the highly flexible HP Coupling protects the driveline of test rigs against critical torsional vibrations. Such vibrations are unavoidable when testing internal combustion engines and put stress on the connected components.

The HP Coupling shifts critical resonance frequencies of the system below the low idle speed and dampens undesired alternating torques. This increases the service life of all drive components of the test rig.

Realistic test results in bell-house mounted arrangements

In past years, a new way of testing has become more and more popular. To get results that largely correspond to everyday conditions, test engineers rely on bell-house mounted arrangements instead of cardan shaft arrangements. In this process, a realistic dummy gear box is flange-mounted to the internal combustion engine, thus simulating the driveline in a vehicle to a very great degree.

Even with this new test procedure, the HP Coupling provides maximum protection for the test rig thanks to reinforced spring assemblies, an enhanced coupling seal and a damping grease optimized for high temperature.

The HP Coupling is wear-free, requires no maintenance and can be adapted to all customer connections

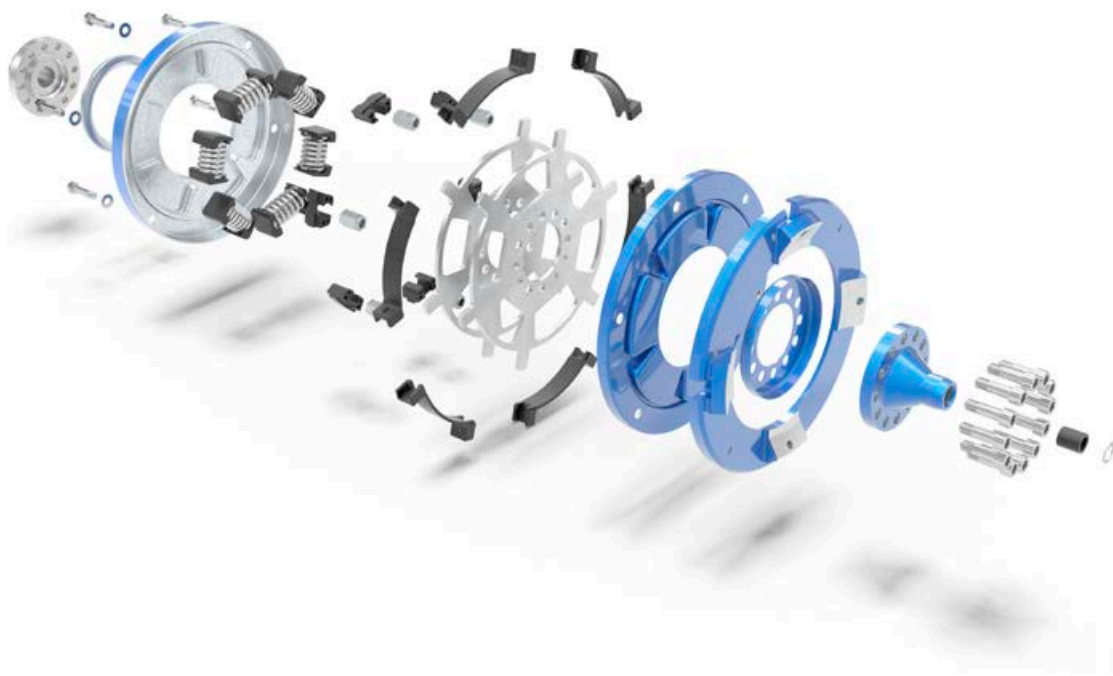



apicom

Power & Efficiency

apicom
Groupe GMB Invest / ICM

Customized and fine adjusted spring assemblies

The springs operate reliably over a wide speed range allowing test runs of up to 8 500 rpm. Up to 16 different spring stiffness values are available, which allow a multi-stage stiffness characteristic of the coupling. Consequently, the coupling can be finely adjusted with precision to the requirements of the customer.

A special temperature-resistant PEEK material increases the spring assemblies' resistance to wear, temperature and strength at high speed. The temperature-optimized grease provides better damping that reduces alternating torques in the driveline to a minimum. This increases the service life of all components connected in the test rig.

Voith Hydrodamp further tailored to test rig requirements

The additional visco-hydraulic damping of the HP Coupling increases the damping effect in proportion to the coupling's angle of twist (Fig. 1). This is the decisive benefit over arc spring couplings used in bell-house mounted test rig arrangements. Severe torsional vibrations, such as those occurring in typical test scenarios, also lead to high damping in this case.

HP Coupling open

The innovative design with speed proportional vibration damping.



During low torsional vibration, the HP Coupling operates in the isolation range where the damping ring absorbs and isolates vibrations within the defined backlash range (Fig. 2). This keeps the power loss of the test rig at a minimum and allows very precise test results. The viscous-hydraulic damping and the isolation function give the coupling optimal damping behavior across the entire nominal speed range.

Features

Connections	adapted to customer requirements
Max. temperature	150 °C
Max. torque	1 600 Nm
Max. speed	8 500 rpm
Weight	~15 kg*
Stiffness adaption	multi-stage

*Depends on customer connections

Example stiffness characteristics

The HP coupling can be precisely adapted by alignment of the curve and damping characteristics to the specific driveline requirements.

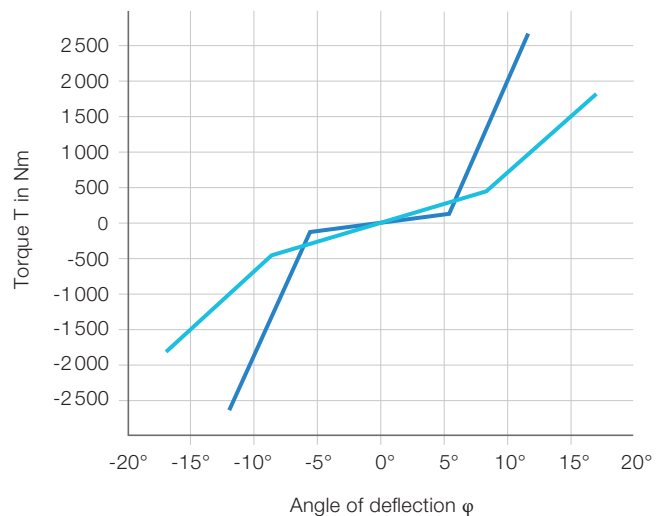

Function of vibration damping (Fig. 1)

If load amplitudes are increased, the hydraulic damping system dampens the occurring vibration amplitudes.



- 1 Floating damping ring with segments
- 2a Pressure side of the damping chambers
- 2b Suction side of the damping chambers
- 3 Free movement (backlash between damping ring and secondary mass)
- 4 Damping gap
- 5 Damping medium
- 6 Primary mass
- 7 Secondary mass

Function of vibration isolation (Fig. 2)

Within normal operating range. The isolation system absorbs vibrations.

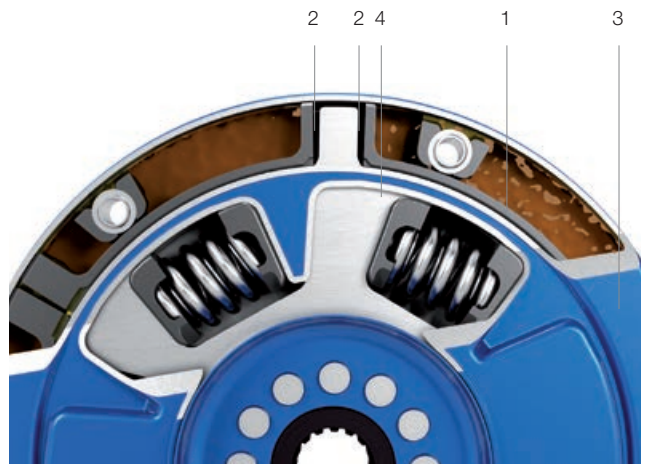

- 1 Floating damping ring with segments
 - 2 Free movement (backlash between damping ring and secondary mass)
 - 3 Primary mass
 - 4 Secondary mass
-

Voith Group
St. Poeltener Str. 43
89522 Heidenheim
Germany

www.voith.com

Contact:
Phone +49 201 557-8361
highflex@voith.com



VOITH
Inspiring Technology
for Generations