

SpeedSizer AT

The highest paper quality due to uniform film application



Consistent dimensional stability

The three most important conditions for perfect film application are flawless premetering, ideally uniform film application and precise transfer of the medium onto the paper web. With SpeedSizer AT, Voith is providing a suitable concept for meeting these conditions, the core of which is the application system. The latter includes the supporting body with attached cross distributor, rod holder and color return system.

The primary element of the application system is the application unit which combines the nozzle applicator, rod holder and color return system. Its dimensional stability must always be ensured regardless of external influences, in particular temperature fluctuations. For that reason the supporting body is made of high-quality, functionally optimized fiber composite material. Thus the SpeedSizer AT achieves lasting precision and outstanding stability, unlike other applicators.

Use of different metering rods

The metering rod is the central element of the metering equipment. Depending on the application and dosage, profiled or smooth metering rods with various diameters are used. The metering element is prepared outside the paper machine as a unit ready to be installed, consisting of a metering rod and metering bed with integrated holder. One of the major advantages of SpeedSizer AT is that thanks to the included SpeedRod M recurring damage to hoses and long shutdown times are made a thing of the past. A quick and easy hose replacement is possible.

Nozzle applicator with liquid seal

In contrast to other products available on the market, SpeedSizer AT has no contacting sealing element. The flexible baffle plate limits the lower area of application, but does not touch the roll.

Your benefits with SpeedSizer AT

- + Excellent application CD profiles
- + Malfunction-free operation
- + Easy maintenance and repair
- + Low energy consumption
- + Quick and easy cleaning
- + Optimal running characteristics

The gap between the plate and roll is sealed by the application medium and thus at the same time prevents the air layer carried along from entering. This system of contactless seal reliably rinses fibers and deposits from the roll and in addition prevents wear on the baffle plate and roll, which in turn leads to shorter shutdown and maintenance times.

Easy cleaning

The cleaning process is made far easier with SpeedSizer AT. The application equipment is automatically rinsed with each stoppage of SpeedSizer AT and with every break due to automatically running rinsing sequences in the entire system. SpeedSizer AT also offers an especially high level of user friendliness due to optimal access and cleaning. Cleaning and changing the metering element are especially easy to do.

Key components of SpeedSizer AT

- | | | |
|-----------------|-------------------|-------------------|
| 1 Machine frame | 2 Applicator roll | 3 Supporting body |
| 4 Applicator | 5 Edge doctor | 6 Save-all pan |

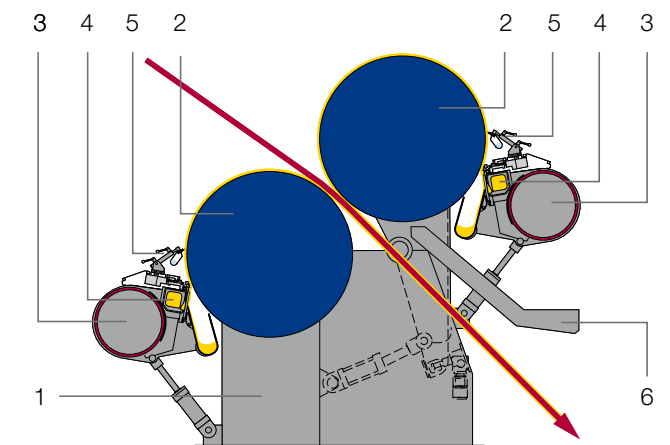

Contact

Asia: Kunshan, China	Tel: +86 512 5799 3600
Europe: Heidenheim, Germany	Tel: +49 7321 37 2487
North America: Wilson (NC), USA	Tel: +1 252 265 4405
South America: São Paulo, Brazil	Tel: +55 11 3944 4966

Further Information



paper@voith.com
www.voith.com/paper

VOITH
Engineered Reliability